

**NOTES:**

1. PROPRIETARY, CONFIDENTIAL AND/OR TRADE SECRET. THE CONTENTS OF THIS DOCUMENT ARE THE PROPRIETARY PROPERTY OF WHIPPIE LLC. THIS DOCUMENT IS SUPPLIED WITH THE UNDERSTANDING THAT ITS CONTENTS WILL NOT BE USED FOR ANY PURPOSE OTHER THAN FOR WHICH IT WAS ORIGINALLY INTENDED. THE CONTENTS MAY NOT BE DISCLOSED TO UNAUTHORIZED PARTIES. THIS DOCUMENT MAY NOT BE REPRODUCED IN WHOLE OR IN PART, WITHOUT THE WRITTEN PERMISSION FROM WHIPPIE LLC. COPYRIGHT © 2020 WHIPPIE LLC. ALL RIGHTS RESERVED.
2. PROPOSED CAMPSITES ARE APPROXIMATE AND MAY BE SHIFTED TO BEST FACILITATE THE ENVIRONMENT.
3. LIGHTING POSITIONS ARE APPROXIMATE. LIGHTING IS EASILY SHIFTED AND MOVED BY DESIGN. ALL LIGHTING IN THIS DRAWING IS SOLAR POWERED.
4. MINIMUM LOT AREA REQUIREMENTS IS 6284 SQ. FT. OR .15 ACRES.

**REVISION HISTORY**

REV	DESCRIPTION
IR	INITIAL RELEASE

KELCEADEN

DO NOT SCALE DRAWING		WHIPPIE LLC	
DRAWING APPROVALS		DWG TITLE	
DESIGN	S. WHIPPIE	WHIPPIE WOODS LAYOUT	
CHECK	S. WHIPPIE		
APP'D	WHIPPIE LLC		
APP'D			
APP'D			
APP'D			
DRAWING RELEASE DATE		SIZE	DWG NO.
04/09/2022		D	85-ST-MT-001
SCALE 1/8"=1'		AUTOCAD	SHEET 1 OF 5
		REV	IR



RELEASED

LOT 34 PROPERTY LINE

SMALL STREAM

(LOT 24)

5' WIDE CAMPSITE PATH (EACH SITE)

10' WIDE WALKING PATH

SEE DETAIL A  
(19 PLACES)  
(3 EXISTING, CYAN)

SEE DETAIL D

DETAIL B  
(1 PLACE, EXISTING)

(LOT 34-1)

(LOT 36)

(LOT 35-1)

SEE DETAIL C

4 4 B

(LOT 35)

(STONE MOUNTAIN ROAD)

(LOT 32)

(LOT 6)



1,000.00 ft

500.00 ft

KEY - LEGEND

- EXISTING CAMPSITE / TRAIL / ROAD POSITION
- PLANNED CAMPSITE / TRAIL / ROAD POSITION
- PARKING
- SIGNS
- PROPERTY BORDER
- LIGHTING

WHIPPIE WOODS LAYOUT



PROPRIETARY, CONFIDENTIAL AND/OR TRADE SECRET		SHEET	DWG NO	REV
SCALE: 1/64" = 1'-0"		D	85-ST-MT-001	IR
		AUTOCAD		SHEET 2 OF 5



RELEASED

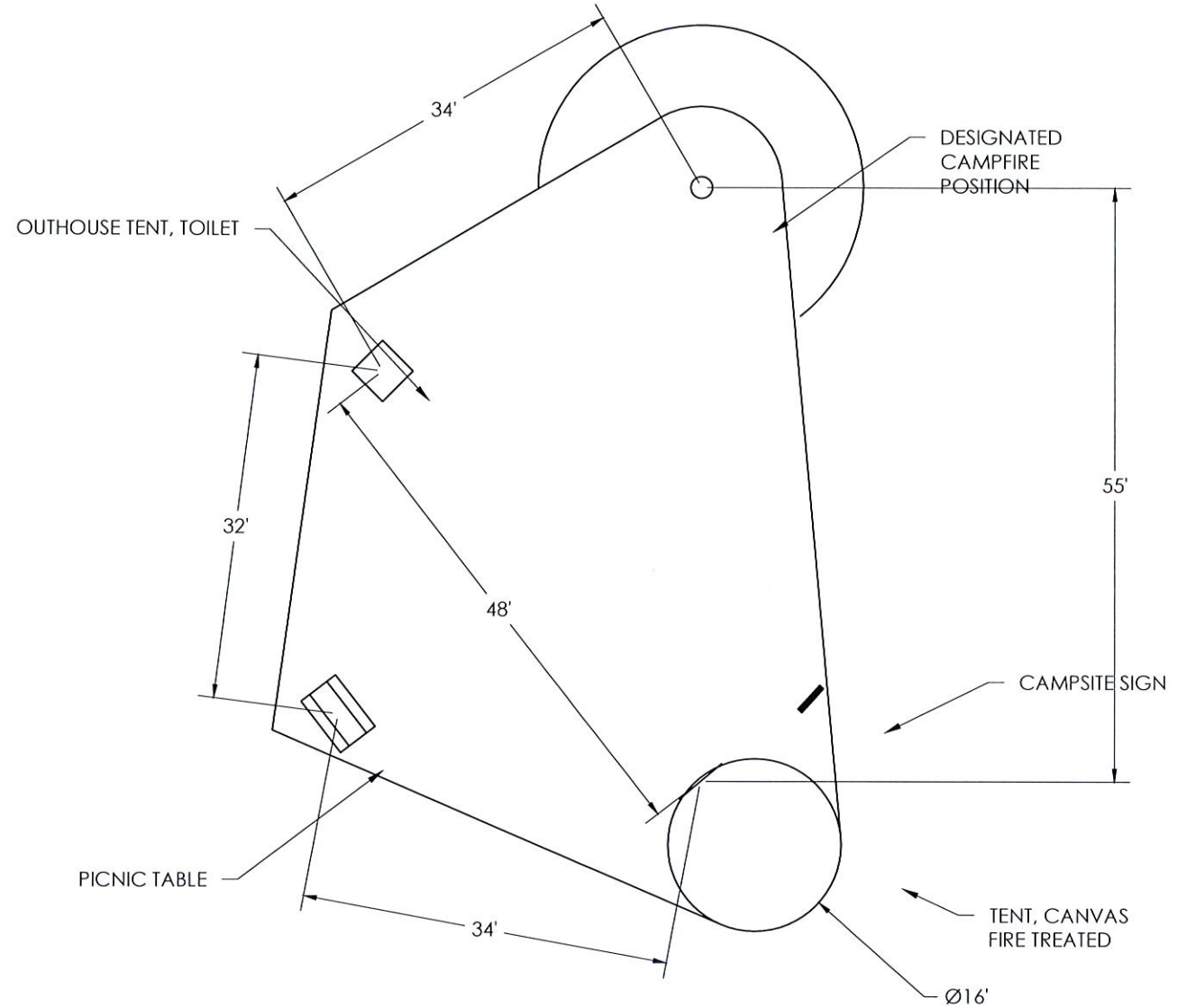

**DETAIL A**  
 16 FOOT BELL TENT  
 (19 PLACES)

2	5
	D

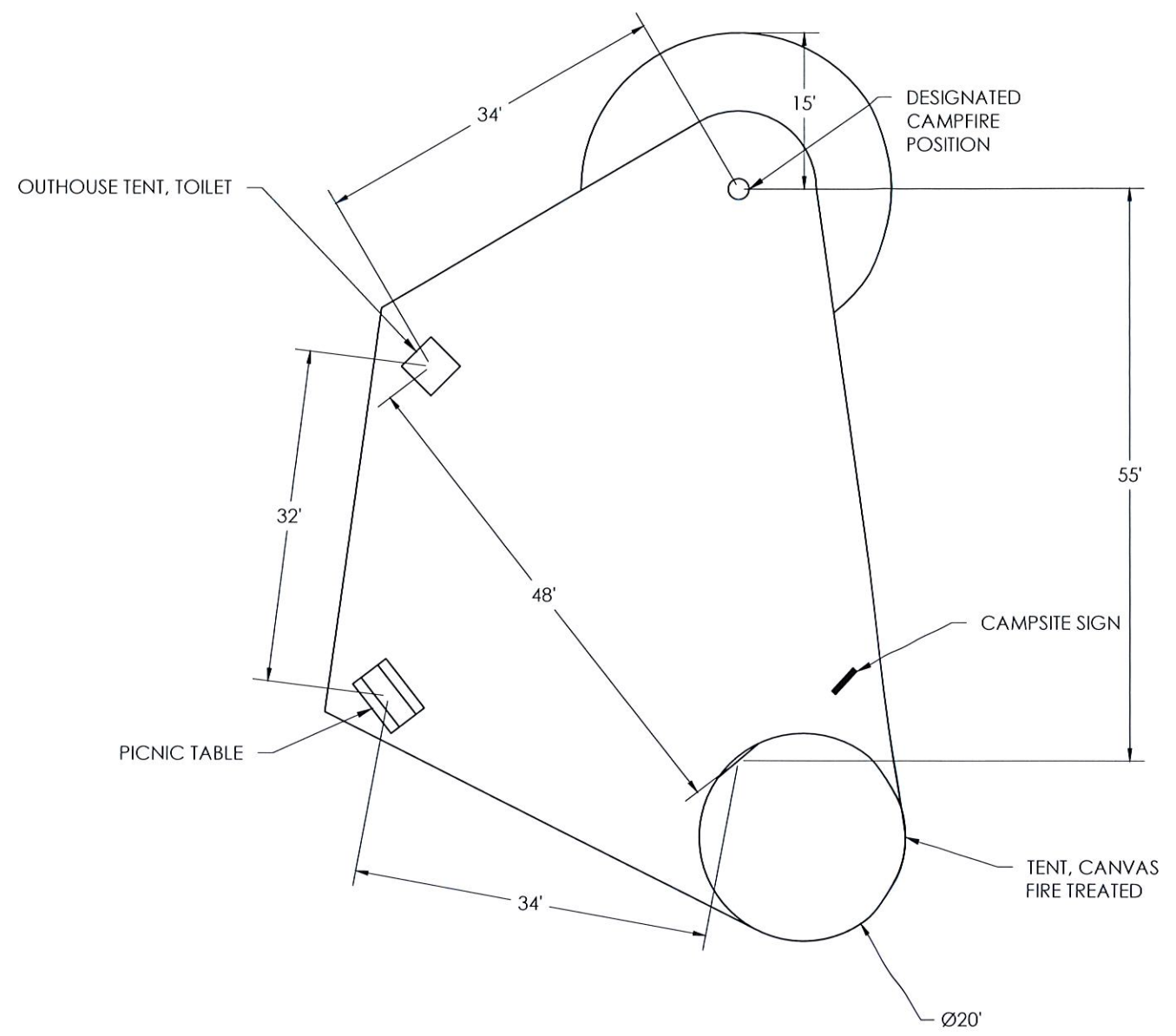

**DETAIL B**  
 20 FOOT BELL TENT  
 (1 PLACE)

2	3
	D

RELEASED

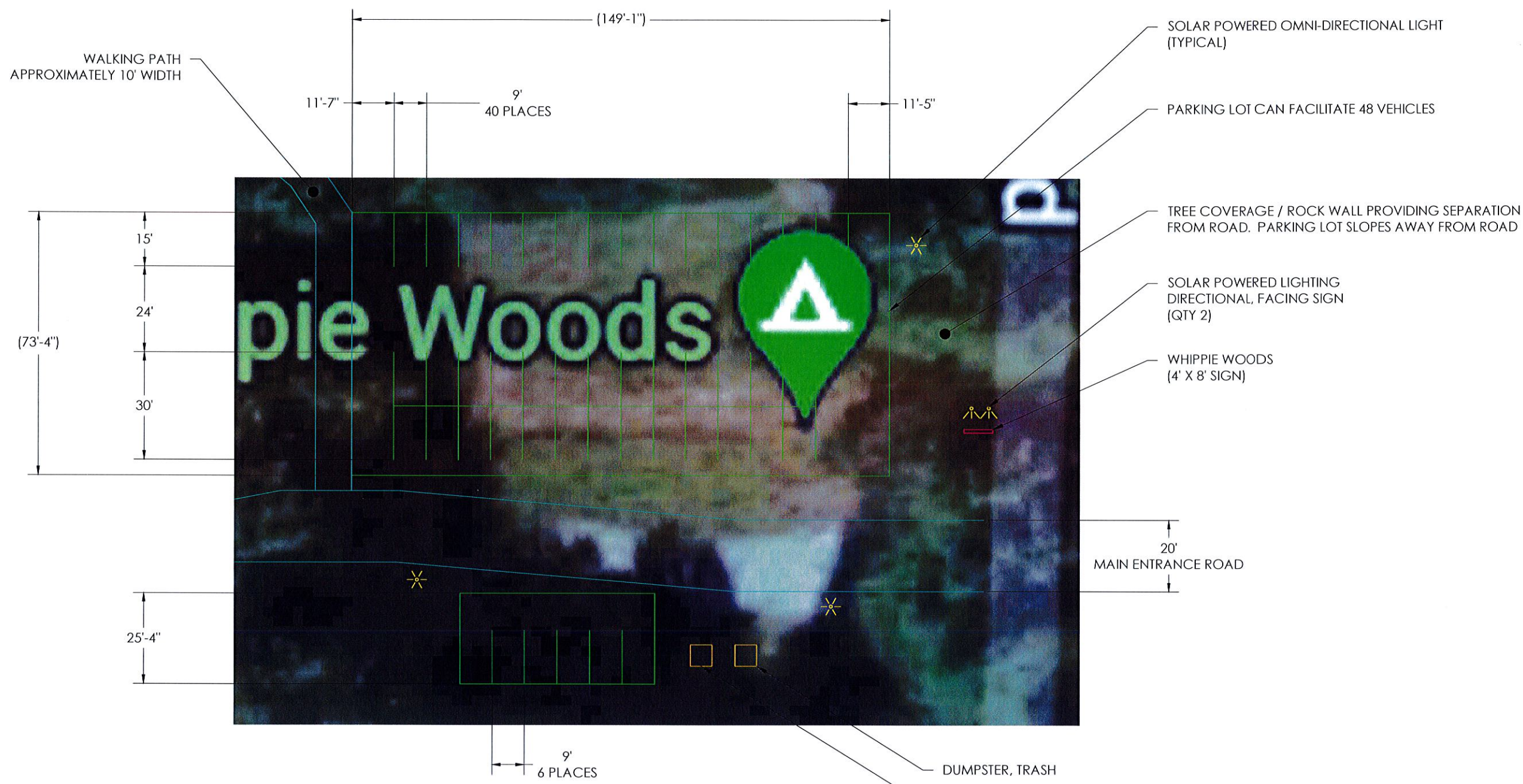

**DETAIL C**  
 PARKING, MAIN ENTRANCE, WASTE COLLECTION

2 | 1  
 D



8 7 6 5 4 3 2 1

D

D

C

C

B

B

A

A

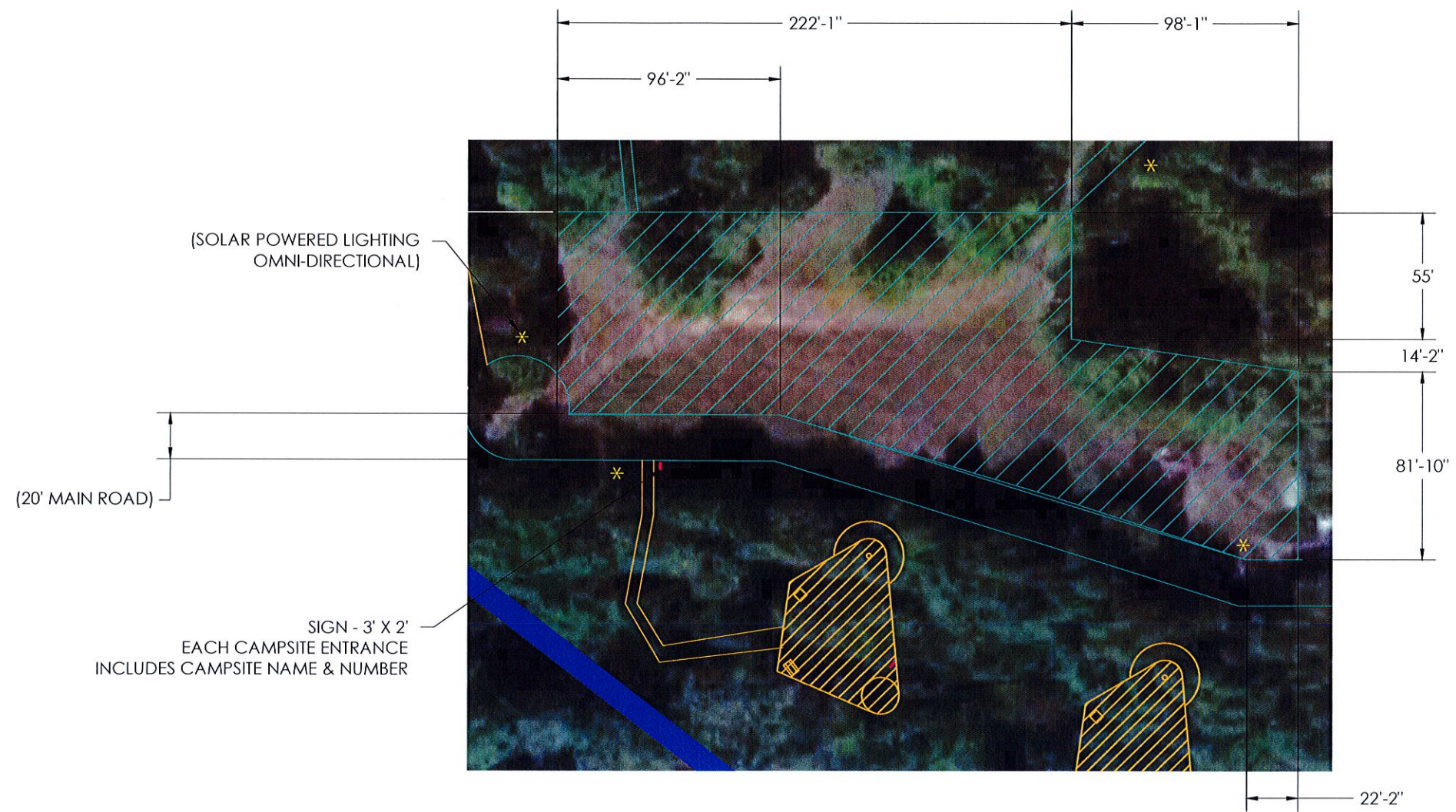

### DETAIL D

FIELD AREA, AVAILABLE FOR RENTALS AND EVENTS. PARKING WILL BE LOCALIZED TO THIS AREA WHEN IN USE

2 4  
D

RELEASED

8 7 6 5 4 3 2 1

PROPRIETARY, CONFIDENTIAL AND/OR TRADE SECRET		SIZE D	DWG NO 85-ST-MT-001	REV IR
SCALE: 1/32" = 1'-0"		AUTOCAD		SHEET 5 OF 5